

ADSL Transformer

For use with Alcatel's DynaMiTe MTK-20140 ADSL chipset

SPECIFICATIONS :

ELECTRICAL :

D.C. RESISTANCE : 1-4 = 7-10 = 1.0 OHMS MAX.

INDUCTANCE : 480 μ H \pm 10%, @ 10KHz , 0.1V 10-7 WITH (8+9 SHORTED)

URNS RATIO : (1-4):(10-7)= 1 : 1 \pm 2%

LEAKAGE INDUCTANCE (1-4) : 10.0 μ H MAX. 300KHz, 0.1V ,(2-3 , 7+10 ,8+9 SHORTED)

T.H.D. : -72 dB MIN. @ 20KHz

INSERTION LOSS : 1.0 dB MAX. @ 100KHz , 1.1 MHz

HI-POT TEST : 1500 VAC

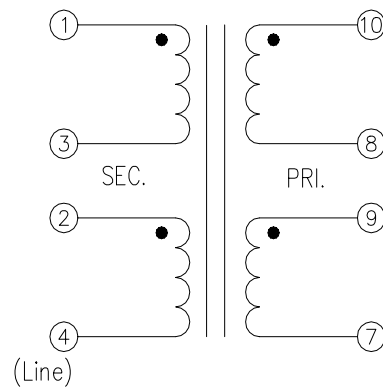
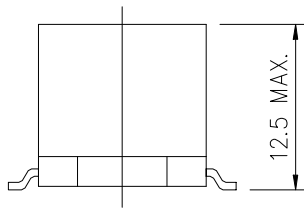

SCHEMATIC

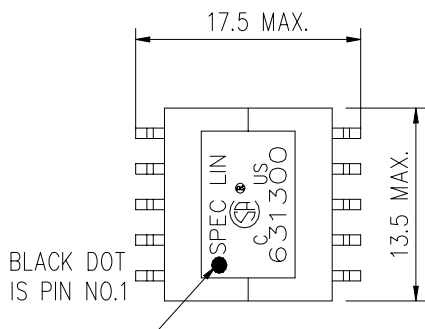

TOP VIEW

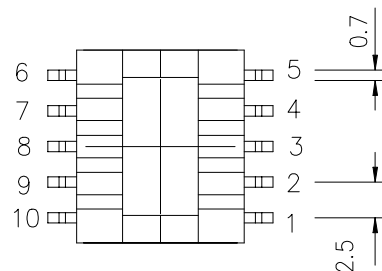

BOTTOM VIEW

SPEC LIN ENTERPRISE CO. LTD.

2F, No. 6, ALLEY 17, LANE 42, CHUNG HSING N.S.T.
SAN CHUNG CITY, TAIPEI, TAIWAN
TEL: 886-2-29991394 FAX: 886-2-22781629

AGENCY NO.

UL NO. : E181559

CSA NO. 186519

ISO 9002: 036809750

DRAWING NO.

631300

UNITS
mm

SHEET
1 OF 1

