

ISDN-U Transformer

SPECIFICATIONS :

ELECTRICAL :

D.C. RESISTANCE : 5-7 = 8.0 OHMS MAX. @ 20°C

12-2 = 12 OHMS MAX. (TIE 1+11)

TURN RATIO : (5-7) : (11-1) = 1 : 1.25 ± 1%

INDUCTANCE : (11-1) = 28 mH ± 10% @ 10KHz, 0.1Vrms TIE(2+12) 80mA

LEAKAGE INDUCTANCE : 5-7 = 60 μH MAX. @ 100KHZ , 0.1Vrms PRI. SHORT

HI-POT TEST : 2.00 KVAC MIN. WINDING & WINDING 1mA FOR 1 MIN.

1.50 KVAC MIN. WINDING & WINDING 1mA FOR 2 SECONDS

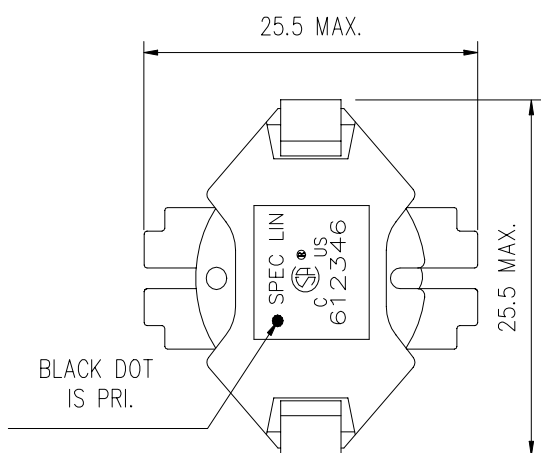
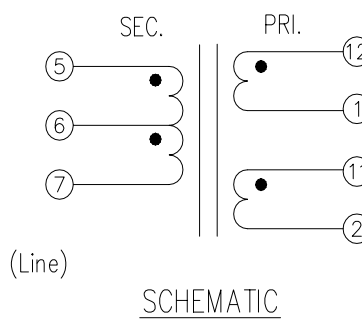
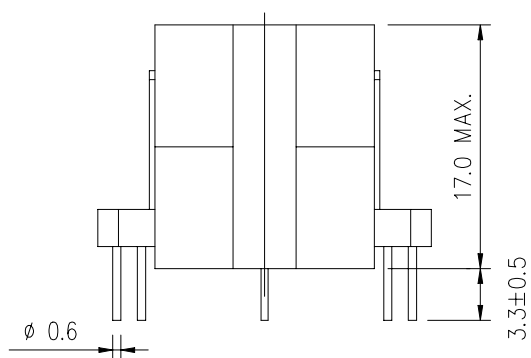

TOP VIEW

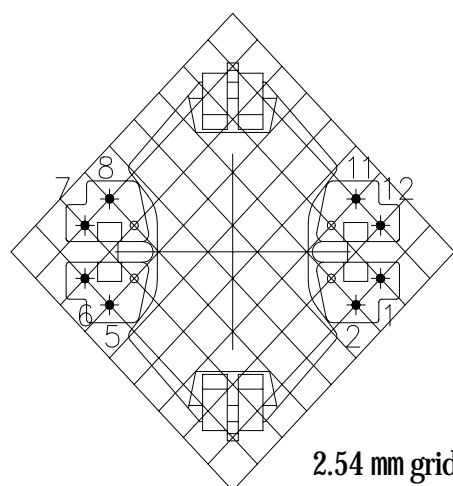

2.54 mm grids

BOTTOM VIEW

SPEC LIN ENTERPRISE CO. LTD.

2F, No.6, ALLEY 17, LANE 42, CHUNG HSING N.ST.
SAN CHUNG CITY, TAIPEI, TAIWAN
TEL: 886-2-29991394 FAX: 886-2-22781629

AGENCY NO.

UL NO. : E181559

CSA NO. : LR107869

ISO 9002: 036809750

DRAWING NO.

612346

UNITS

mm

SHEET

1 OF 1

