

Linear Power Adapters & Transformers

L3C-XYR Series



AC/DC ADAPTERS

TUV NO.: S9853543

UL NO.: E192841

No	Model No.	INPUT(AC)		OUTPUT(DC)		TUV Listed	CE Listed	CB Listed	UL Listed	CUL Listed
		VOLT.	Hz	VOLTAGE	Full Load(mA)					
1	L3C-030035R	120	60	3	350					
2	L3C-030050R	120	60	3	500					
3	L3C-030065R	120	60	3	650					
4	L3C-045035R	120	60	4.5	350					
5	L3C-045050R	120	60	4.5	500					
6	L3C-050045R	120	60	5	450					
7	L3C-060015R	120	60	6	150					
8	L3C-060020R	120	60	6	200					
9	L3C-060025R	120	60	6	250					
10	L3C-060030R	120	60	6	300					
11	L3C-060040R	120	60	6	400					
12	L3C-075015R	120	60	7.5	150					
13	L3C-075020R	120	60	7.5	200					
14	L3C-075025R	120	60	7.5	250					
15	L3C-075030R	120	60	7.5	300					
16	L3C-075035R	120	60	7.5	350					
17	L3C-075040R	120	60	7.5	400					
18	L3C-090010R	120	60	9	100					
19	L3C-090015R	120	60	9	150					
20	L3C-090020R	120	60	9	200					
21	L3C-090025R	120	60	9	250					
22	L3C-090030R	120	60	9	300					
23	L3C-120010R	120	60	12	100					
24	L3C-120015R	120	60	12	150					
25	L3C-120020R	120	60	12	200					
26	L3C-120025R	120	60	12	250					
27	L3C-120030R	120	60	12	300					
28	L3C-150010R	120	60	15	100					
29	L3C-150015R	120	60	15	150					
30	L3C-150020R	120	60	15	200					
31	L3C-180010R	120	60	18	100					
32	L3C-180015R	120	60	18	150					

Linear Power Adapters & Transformers

L3C Series – ULAC/DC

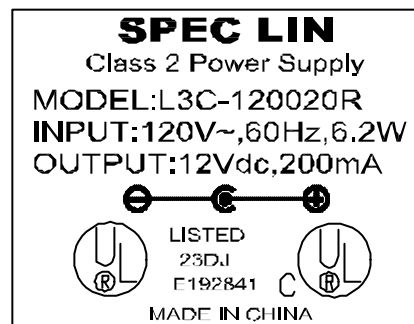
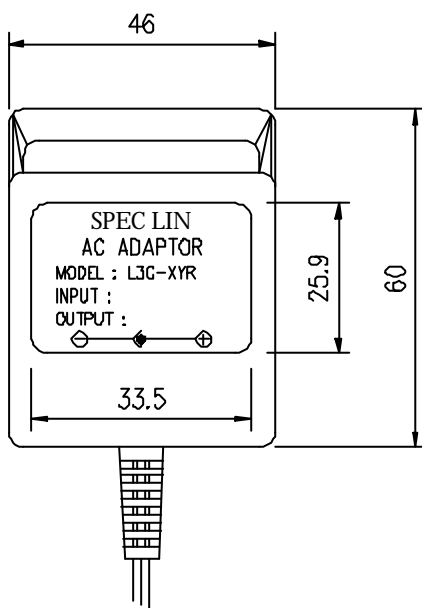
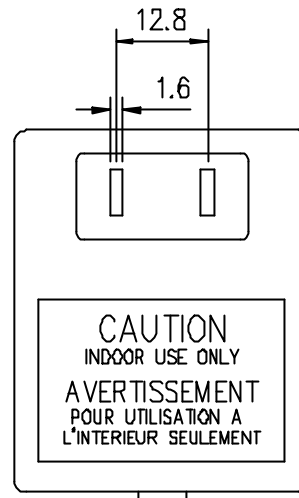
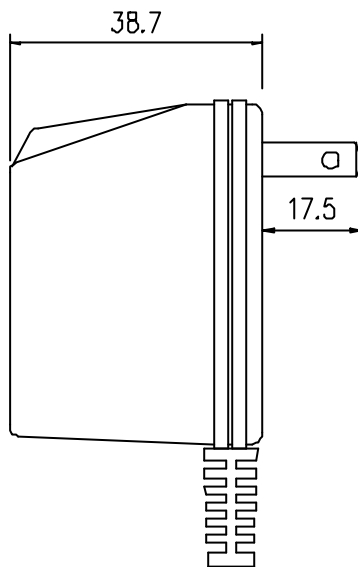

SL Spec Lin Enterprise Co., Ltd.

2F, No. 6, Alley 17, Lane 42, Chung Hsing N. St., San Chung City, Taipei Hsien, Taiwan, R.O.C

TEL : 886-2-2999-1395 FAX : 886-2-2278-1629 Email : speclin@ms22.hinet.net