

# ADSL POTS LOW PASS FILTER FOR CUSTOMER PREMISES

- POTS loop DC currents from 0mA to 100mA
- Excellent longitudinal balance
- Operation temperature -10 to 75°C
- Low Cost

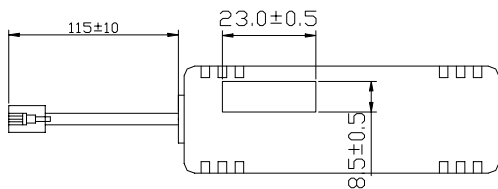
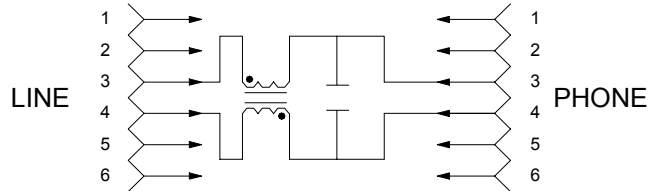
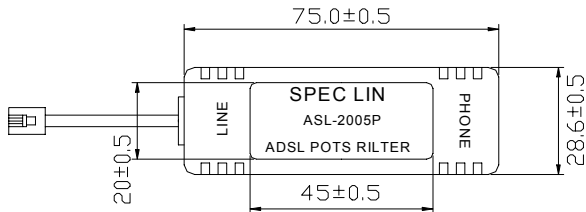

Commector	Function	Style	Tip	Ring
J1	Line	RJ11PLUG	Pin3	Pin4
J2	Phone	RJ11	Pin3	Pin4

## Specifications @ 25 °C

		MIN.	TYP.	MAX.	Unit
Insertion loss	1KHz			0.5	dB
Insertion loss In Voice band	200Hz to 4KHz	-1.0		+1.0	dB
Attenuation distortion	30KHz	20			dB
	80KHz & above	40			dB
Return loss	ERL	14			dB
	SRL - HI	8			dB
	SRL-LO	18			dB
Longitudinal Balance	200Hz to 4KHz	53			dB
DC resistance	EACH LINE			5	ohms
	Tip to ring @ 100VDC	5			Mohms
	Tip or ring to ground @100VDC	10			Mohms
DC current				100	mA

**SPEC LIN ENTERPRISE CO.LTD.**  
**AGENCY NO. ISO 9002 : 036809750**

UNITS:  
mm

DRAWING NO.  
**ASL-2005P**

# SPEC LIN ENTERPRISE CO.,LTD.

## ELECTRICAL CHARACTERISTICS

### 1. Technical Requirement:

#### 1.1 ZHP-r Defined

To facilitate testing of the Low pass filter independently of the actual modem or specific vendor. ZHP-r is defined in Figure E-1 to allow proper termination of xDSL port during. The ZHP is valid only for voice band frequencies. The combination of capacitors in the voice band testing ZHP-r is only representative.

ZHP Remote end

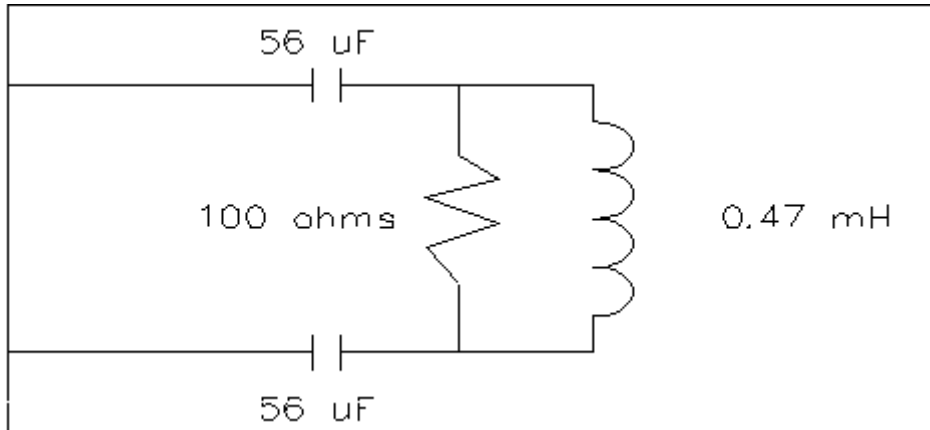

NOTE Component Tolerances: Capacitors:2.5%, Resistors: 1%, Coils: 5%

Figure E-1 ZHP-r definitions

## 1.2 Test method

### 1.2.1 Insertion Loss at 1004 Hz

The test set-up shown in Figure E-2 the insertion loss from the source to the termination shall be measured with and without the Low pass Filter/ZHP-r combination inserted.

The increase in insertion loss at 1004 Hz, due to addition of the Low pass Filter/ZHP-r, shall as follows specifications.

### 1.2.2 Attenuation Distortion in the Voice Band

The variation of insertion loss with frequency shall be measured using the test set up Figure E-2. The defined ZHP-r will be attached to the LINE port of the Low pass Filter. If the Low pass Filter is an internal part of the ATU, then the modem remains attached as the xDSL load. The increase in attenuation distortion, relative to the 1004 KHz insertion loss, caused by the Low pass Filter with the ZHP-r (or modem) load.

Figure E-2 defines the test configuration and the value of the test components that shall be used for transmission measurements in the voice band Remote Low pass Filter.

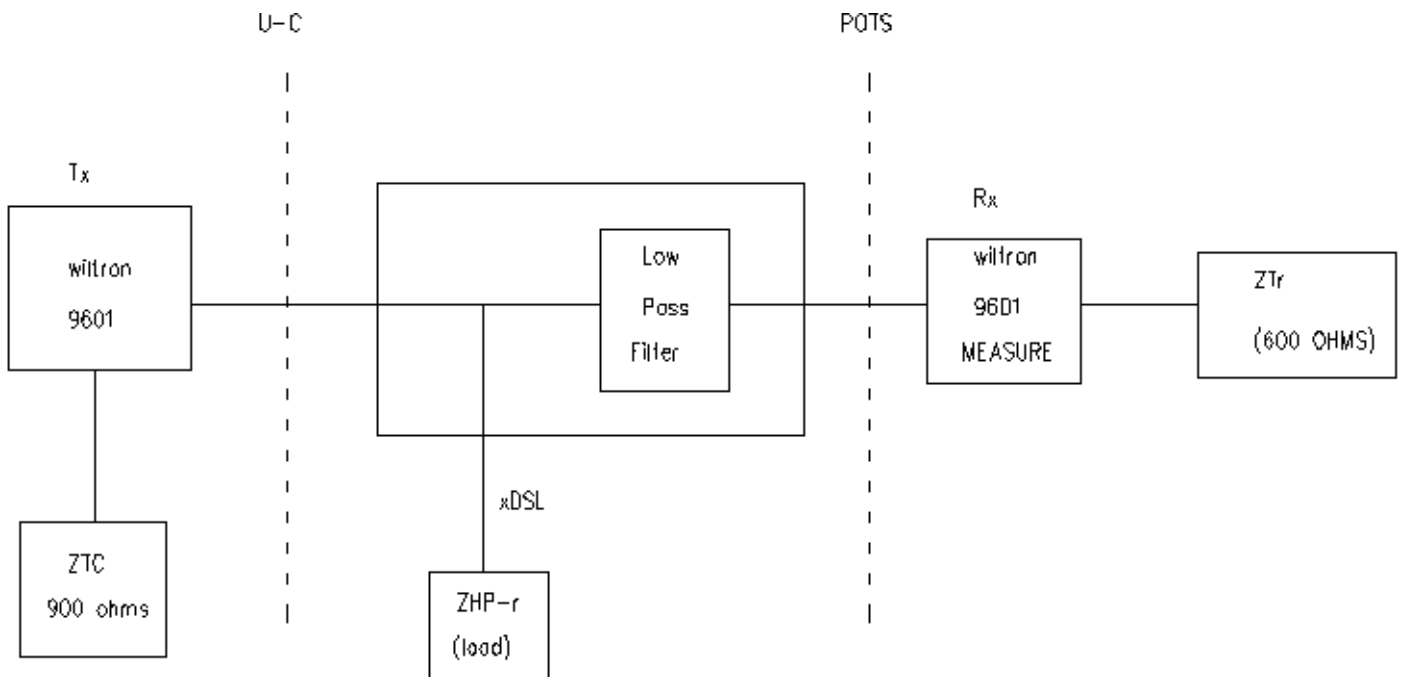



Figure E-2 Transmission measurements in voice band for the Loss pass Filter

### 1.3.3 Return Loss

Figure E-3 defines the test configuration and the components that shall be used for transmission measurements in the voice band for the Remote Low pass Filter.

Where:

  $Z_{NL-r} = 1330 \text{ ohms} // (348 \text{ ohms} + 100\mu\text{F})$

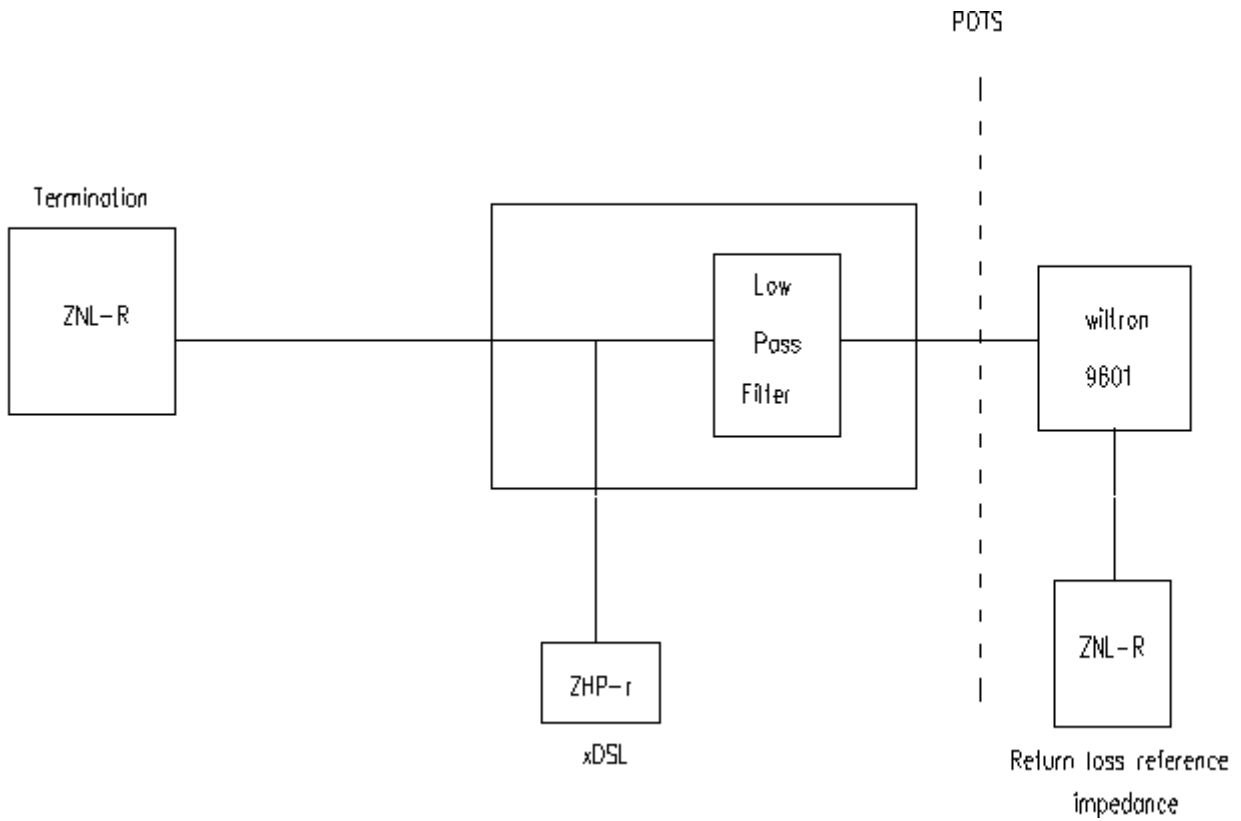

Figure E-3-Remote POTS splitter Return Loss Set Up

### 1.2.4 Longitudinal Balance test

The longitudinal balance of the Low pass Filter shall be greater than 58 dB for frequencies ranging from 0.2 to 4.0 KHz.

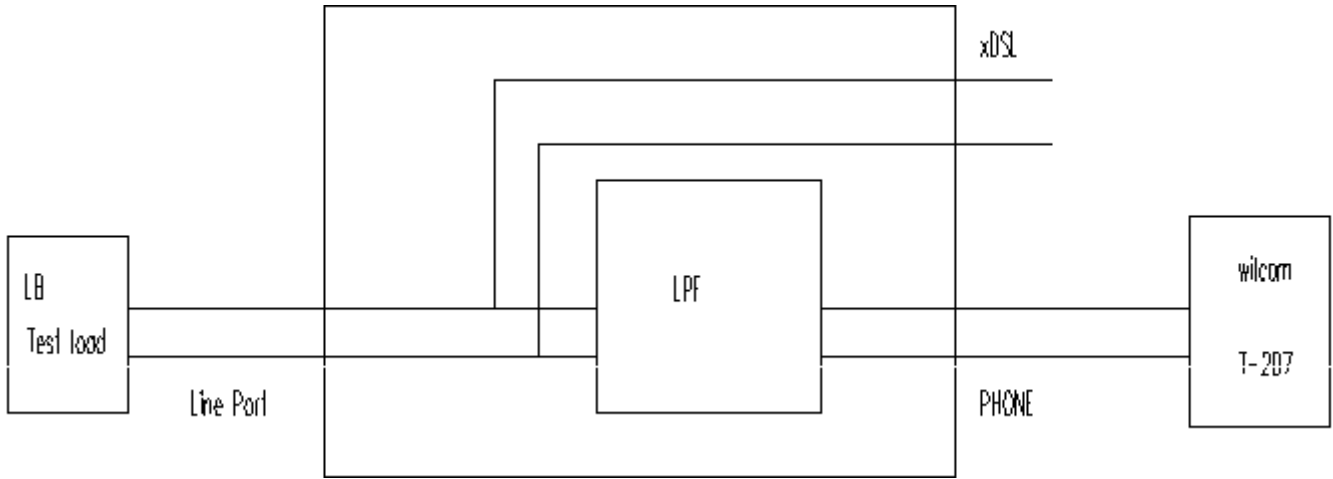

Figure E-4-Longitudinal Balance Remote Setup per IEEE 455

### 1.2.5 ADSL band Attenuation

The attenuation in the stop band of the Low pass Filter. Shown in Figure E-5 shall be greater than 20 dB for frequencies ranging from 30 KHz to 80 KHz and 40dB for frequencies ranging from 80 KHz ~ 1104 KHz with an input level of 10 dBm.

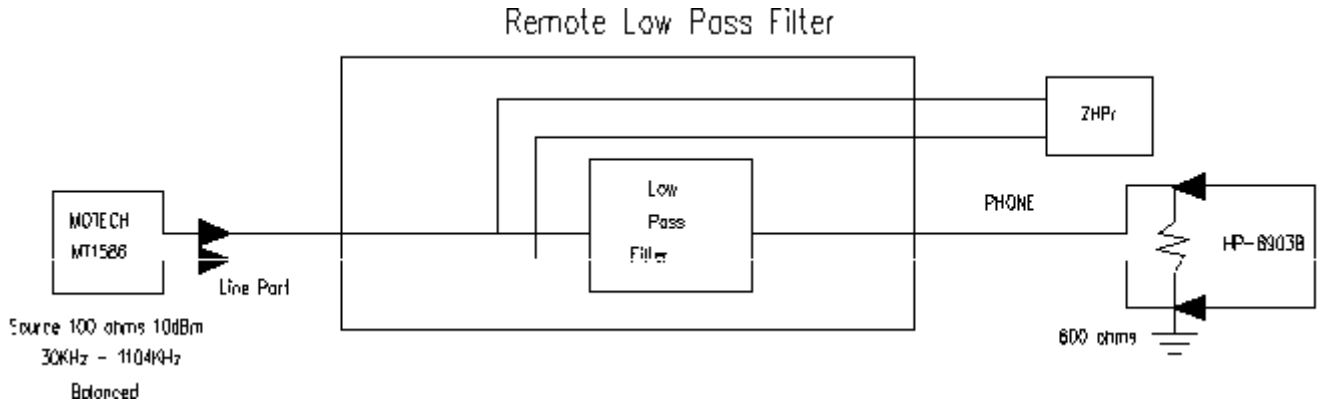

Figure E-5-Measurement of the Remote splitter attenuaton in the ADSL Band

### 1.4 Test Apparufus:

- A. WILTRON MIDEL 9601 TRANSMISSION MEASUREMENT SET
- B. WILCOM MIDEL T-207 LONGITUDINAL BALANCE TEST SET
- C. SPIRENT DLS-400 xDSL WIRELINE SIMULATOR
- D. MOTTECH MT 1586 WIDE BAND TRANSMISSION LINE TESTER
- E. HP-8903B AUDIO ANALYZER