

ADSL POTS LOW PASS FILTER FOR CUSTOMER PREMISES

- POTS loop DC currents from 0mA to 100mA
- Excellent longitudinal balance
- Operation temperature -10 to 75°C

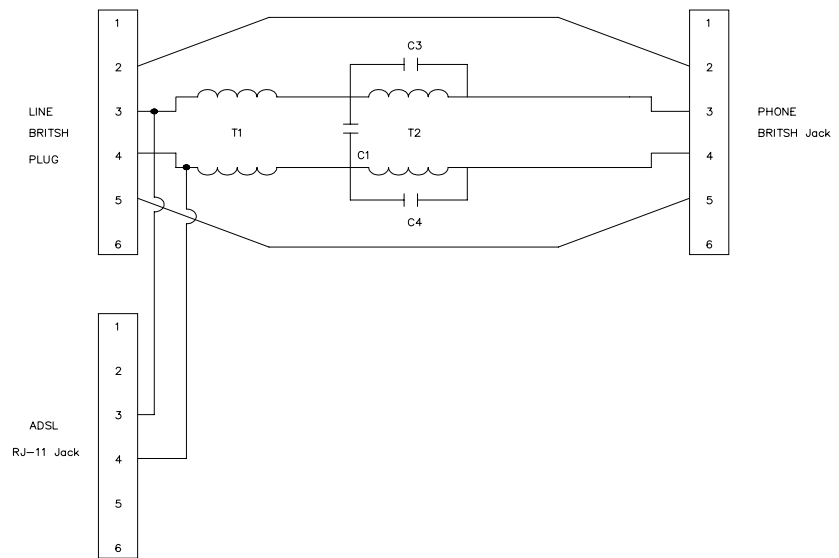

Specifications @25 °C

		MIN.	TYP.	MAX.	Unit
Insertion loss with 5 Filters used in parallel	1KHz			1.0	dB
Attenuation Distortion					dB
In Voice band	200Hz to 4KHz	-1.0		+1.0	dB
In ADSL band	32KHz – 110KHz			-45	dB
Return loss with 5 filters used in parallel	ERL	8			dB
	SRL – HI	4			dB
	SRL-LO	16			dB
Longitudinal Balance	200Hz to 4KHz	53			dB
DC resistance	EACH LINE			25	ohms
	Tip to ring @ 100VDC	10			Mohms
	Tip or ring to ground @100VDC	10			Mohms
DC current				100	mA

SPEC LIN ENTERPRISE CO.LTD.
AGENCY NO. ISO 9002 : 036809750

UNITS: mm

DRAWING NO.

ASL-2011